

APPLICATIONS

- Residential Water Wells
- Landscape Irrigation
- Whole-House Protection
- Pre-Filters Water Treatment
- Any Pressurized Water System
- Reclaimed Water System

Flow Range
up to 150 gpm
(34 m³/hr)

Maximum Pressure Rating
100 psi
(6.9 bar)

Model Sizes
3/4", 1", 1 1/2", 2"
inlet/outlet

5 Different Filter Elements

30 mesh (600 Microns) • 60 mesh (250 microns) • 100 mesh (150 microns)
• 140 mesh (105 microns) • 200 mesh (74 microns)

Exclusive Reverse-Flush Technology

Patented reverse-flush action actually reverses the flow of water to push all of the dirt off and out of the filter.

No Messy Disassembly

No need to take the filter apart to scrub the mesh—simply twist and clean!

Larger Screen Mesh Area

A larger filter element means more time between flushes and less hassle for you.

Durable Stainless-Steel Screens

Stronger and more durable than common nylon screens for a much longer life.

Eliminates Build Up of Filter Cake

The filter is fully cleaned with each flush. No lingering or stuck particles means no build up that you'll have to clean out.

Glass-Filled Polypropylene Body Resists UV

UV resistant body means less yellowing and a longer life.

Viton O-Ring at Flush Port

A strong, durable O-ring at the flush port means maximum strength for a longer life of the filter.



HOW DOES IT WORK?

Traditional filters use ineffective “rinse” methods which leave sediment trapped in the screen. When these screens become clogged, frequent cleanings and damaged screens become a common occurrence. With the TwistII Clean Water Filters patented reverse-flush technology reverses the flow of water to push all of the dirt off and out of the filter. This means no messy disassembly, no particle buildup, and more time between flushes.

PATENTED REVERSE FLUSHING ACTION WITH 1/4 TURN OF THE HANDLE:

1. Flow direction through the filter element is changed to inside-out.
2. The filter element is lifted to open the bottom flush port.
3. An inside-out backwash occurs and the filter element is thoroughly cleaned.

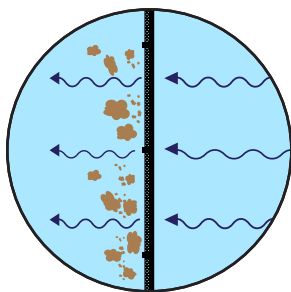
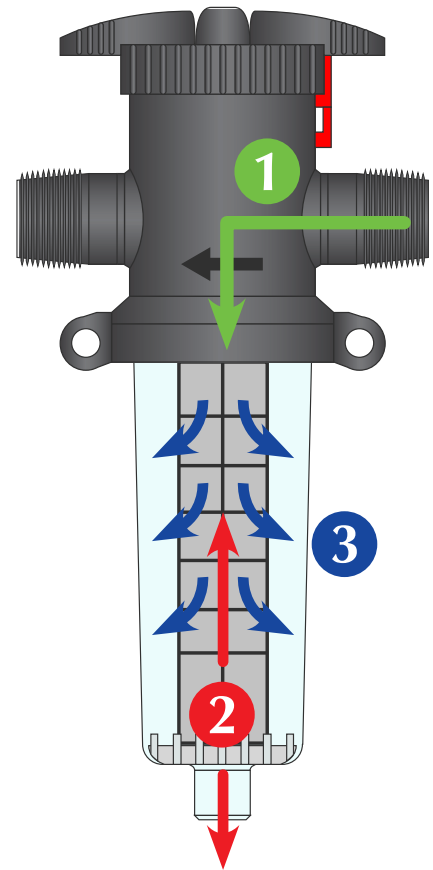

Only **TwistII Clean** filters use reverse-flush action to **completely clean** the screen.

VS.

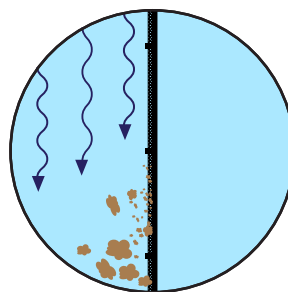

Traditional screens use ineffective wash-by action, leaving sediment trapped in the screen.

Avoid Common Problems of Traditional Filters



**Messy
Disassembly**



**Particle
Buildup**



**Broken
Components**

SELECTING THE RIGHT TWISTIICLEAN

THINGS TO TAKE INTO CONSIDERATION

1. Flow rate of system
2. Pressure loss expectations
3. Particle load of application
4. What you are protecting

CHOOSE A MODEL

Model Details						
Model	Max Flow Rate		Inlet/Outlet Size	Effective Screen Surface Area		Screen Flush Size
	U.S. gpm	m ³ /hri		in ²	cm ²	NPT male
T2C-075	25	5.5	¾ in. male NPT	12.02	77.5	½ in.
T2C-100	39	8.91	1 in. male NPT	12.02	77.5	¾ in.
T2C-150	78	17.71	1½ in. male NPT	24.79	159.9	¾ in.
T2C-200	150	34.0	2 in. flanged	55.5	358.1	¾ in.



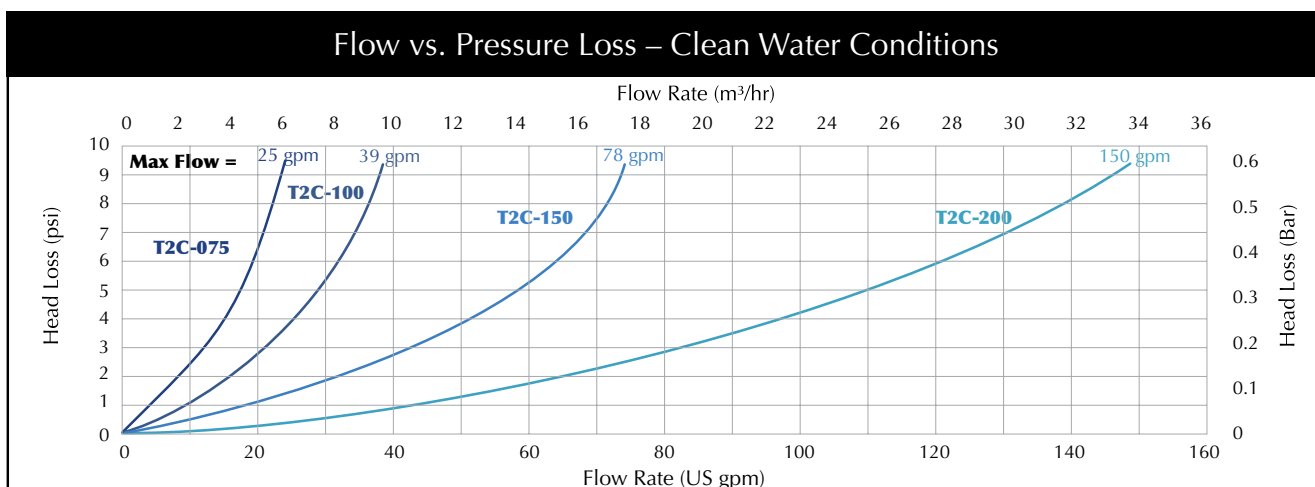

Maximum Pressure: 100 psi (6.9 bar)

Maximum Temperature: 120°F (49°C)

VERIFY PRESSURE LOSS

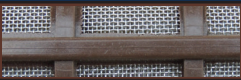
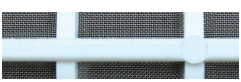

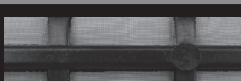
CHOOSE A FILTER ELEMENT

Screen Element Options			
Part Number	Color of Element	Screen Mesh Size	Common Applications
¾" & 1" : 131730 1½" : 132232		30 Mesh 600 Microns	Removal of large particle matter. Pre-filtering ahead of other filters or devices. Large orifice impact sprinklers.
¾" & 1" : 131731 1½" : 132233 2" : 131743		60 Mesh 250 Microns	Typical landscape sprinklers. Pre-filter to fine cartridge filters.
¾" & 1" : 131732 1½" : 132234 2" : 131744		100 Mesh 150 Microns	Most popular size. Used for residential systems and pre-filtering before water treatment systems.
¾" & 1" : 131733 1½" : 132235 2" : 131745		140 Mesh 105 Microns	drip-irrigation, micro-sprays, spray nozzles, misting systems
¾" & 1" : 134271 1½" : 134272 2" : 131746		200 Mesh 74 Microns	Greatest protection. Often used on water treatment systems.

TECHNICAL SPECIFICATIONS

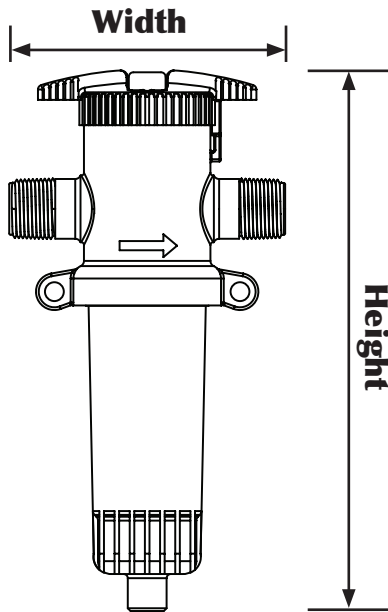

Model	Height		Width		Weight		Weight with Water	
	in.	mm	in.	mm	lbs	kg	lbs	kg
T2C-075	11-7/8	301	6	152	2	.91	3	1.36
T2C-100	11-7/8	301	6	152	2	.91	3	1.36
T2C-150	15-1/4	387	7-1/2	191	6	2.72	9	4.08
T2C-200	25-15/16	634	10-1/4	260	11	4.99	19	8.62

TECHNICAL INFORMATION

Materials of Construction

- Body: Glass-filled Polypropylene
- Clear Bowl: Polycarbonate
- Seals: EPDM; Flush Port O-ring is Viton
- SunShield: Neoprene

General Guidelines

- Filter is for use with water only. Evaluate any chemicals in the water for proper usage with the filter.
- Filter is suitable for any pressurized water system including, but not limited to: residential, landscape irrigation, reclaimed water, whole house protection, agriculture, and commercial systems.
- Protect unit from freezing, as you would with any other water lines.
- Install in cold water line that feeds the water heater. Do not use with hot water.
- Install filter in mostly vertical position.
- Offset from walls to allow for cleaning.
- Allow for clearance below to flush and remove lower bowl.



Certified to
NSF/ANSI/CAN 61
& NSF/ANSI 372



Nominated for
Best Product
of the Year at
World Ag Expo



TWISTIICLEAN SUNSHIELD

Optional SunShield protects polycarbonate bowl from discoloring and the internal screen from excessive algae growth when the TwistIIClean filter is installed in a sunny location. Easily slides on for installation and down for inspecting the screen.



TWISTIICLEAN
WATER FILTER

cs@twisticlean.com
833-834-5837 (1-833-8FILTER)
PO Box 150267 Ogden, UT 84415